

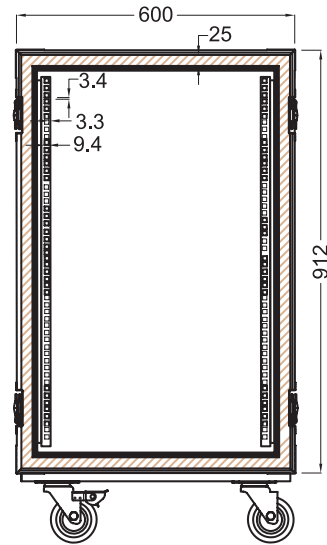

TWIN DOOR ROLL RACK CASE

A Rhino branded 19" rackmount Flight Case. Finished in black. Removable front and rear doors with double butterfly clasps. Double fold-flat handle on two faces. Four casters supplied. Shockproofing provided by 25mm dense foam.

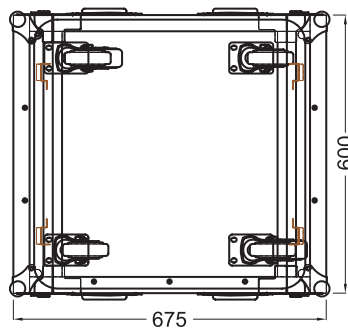
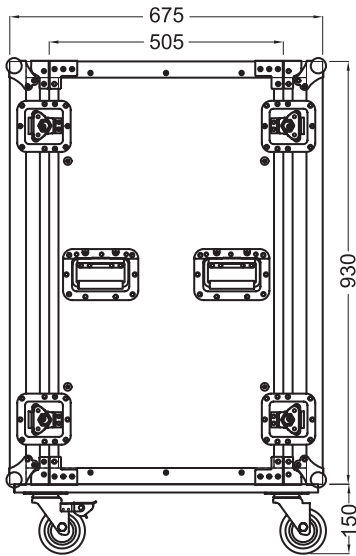

Model Number: RHCA12U
Order Code: J01188

12u

Model Number: RHCA14U
Order Code: J01205

14u

Model Number: RHCA16U
Order Code: J01290

16u

Model Number: RHCA18U
Order Code: J01443

18u

Model Number: RHCA20U
Order Code: J01511

20u

Order Code	Width (mm)	Height (mm)	Depth (mm)	Weight (mm)
J01188	600	820	675	42.0
J01205	600	900	675	44.8
J01290	600	980	675	49.0
J01443	600	1080	675	53.0
J01511	600	1180	675	55.5

Schematic shown for Order Code J01511

